

8 7 6 5 4 3 2 1

F
E
D
C
B
A

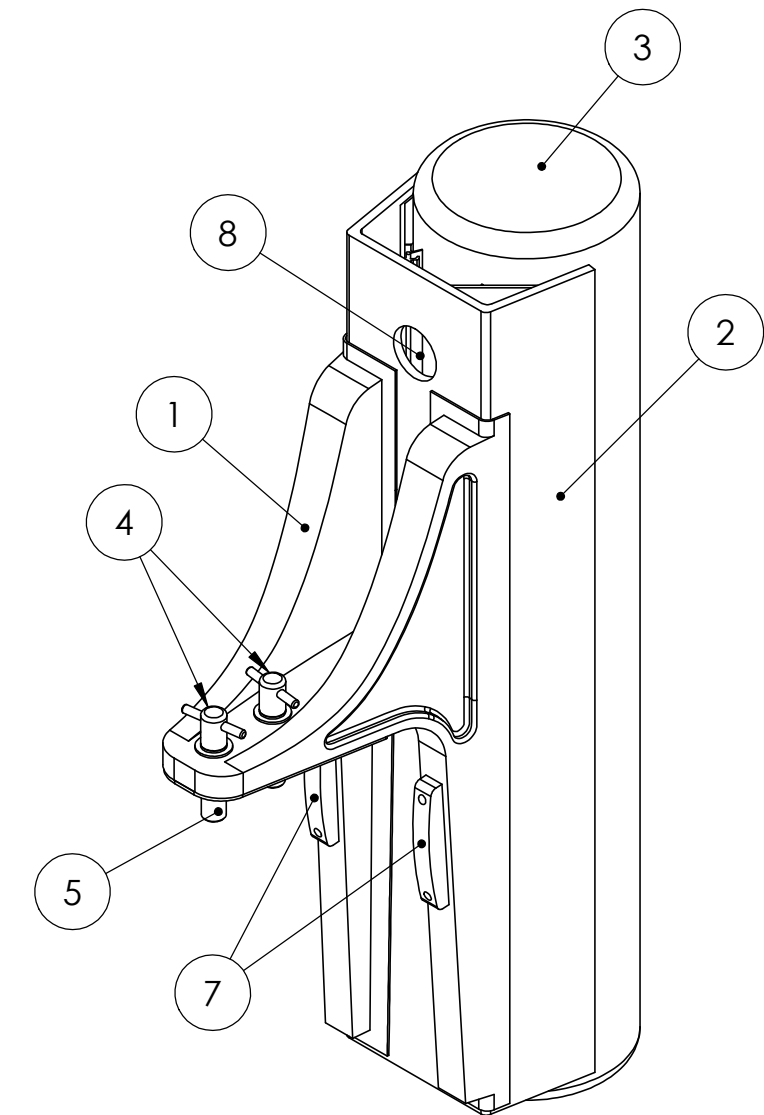
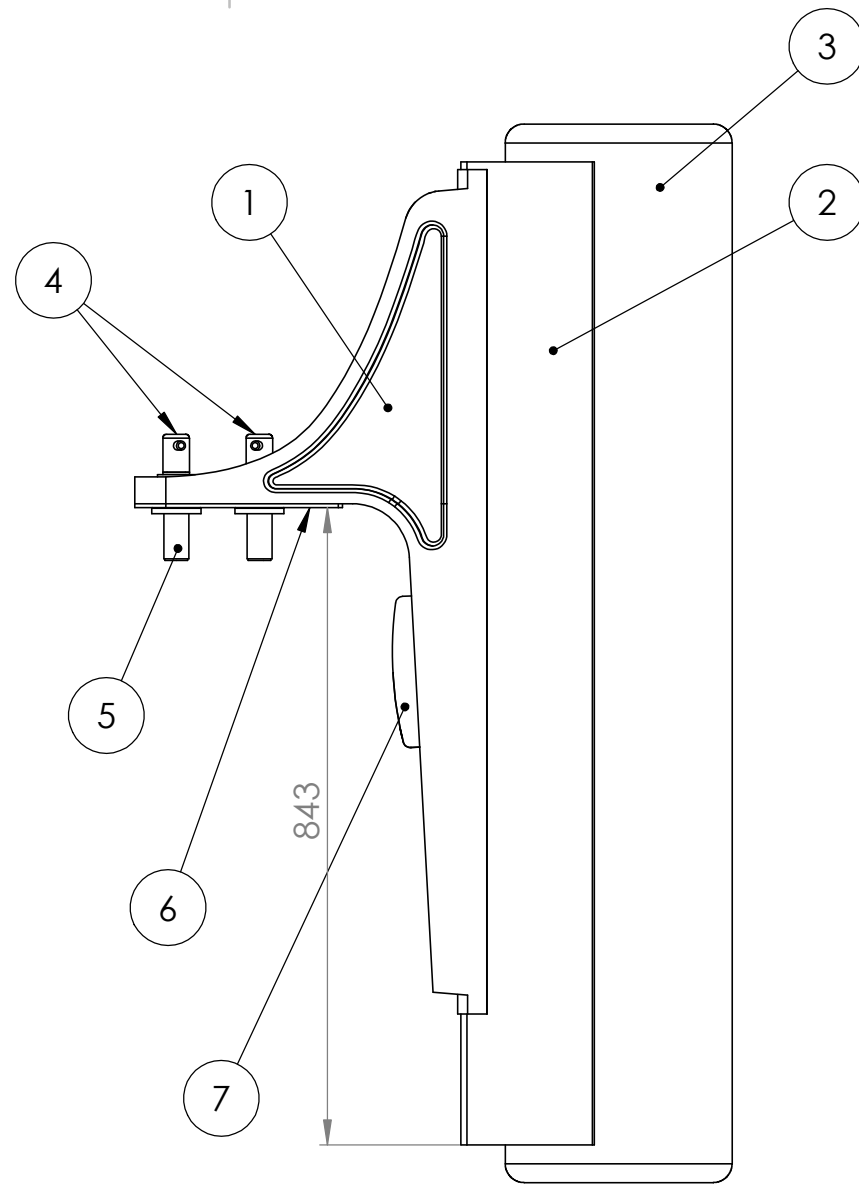
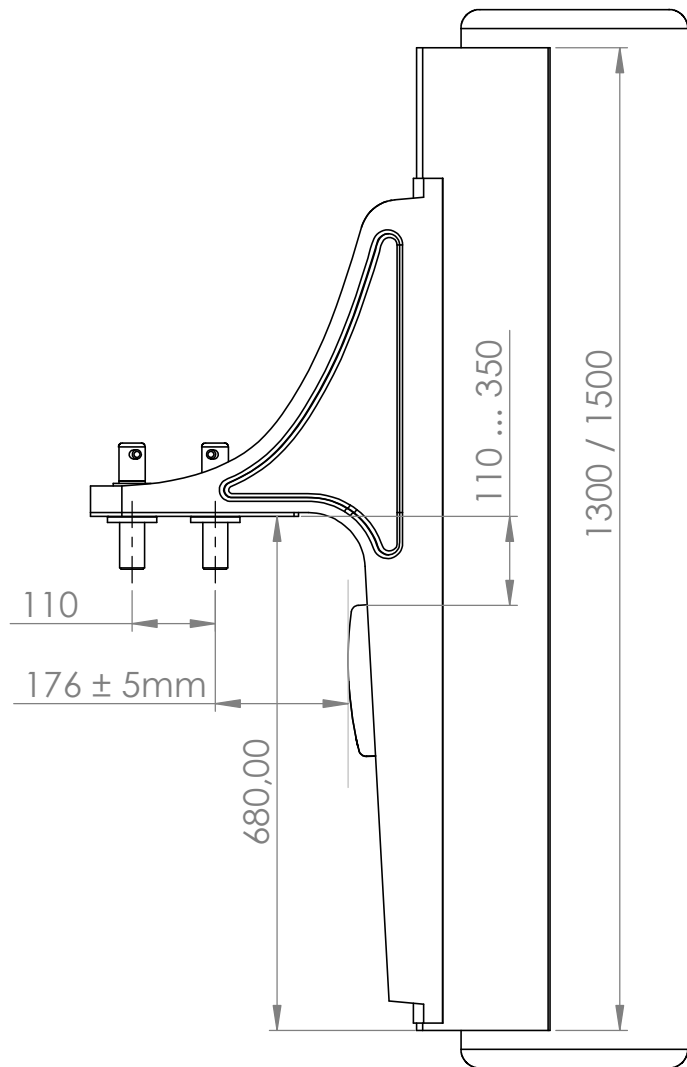
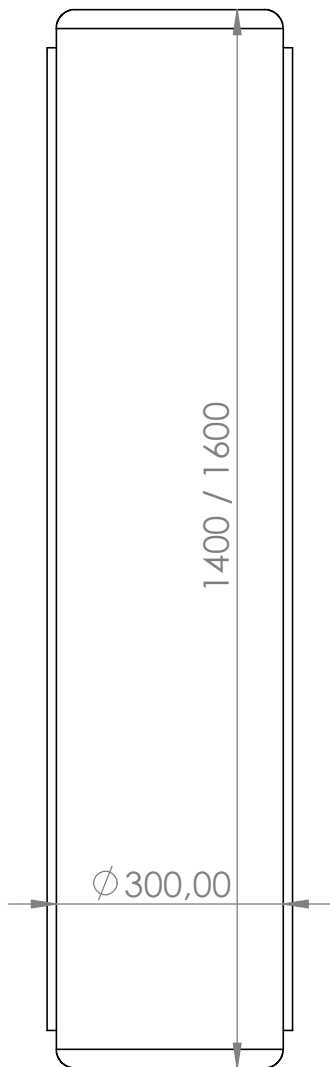

NOTE: Basement structure may have any height between the two values indicated

ID	DESCRIPTION	MATERIAL
1	Basement Structure	Carbon.epoxy
2	Fender Structure	Carbon.epoxy
3	Inflatable Hypalone	
4	Connection pin with "T" cleat	Stainless steel
5	Deck socket	Stainless steel
6	Deck protection	Nylon - natural white / black
7	Lower protection	Nylon - natural white / black
8	Hypalone valve	

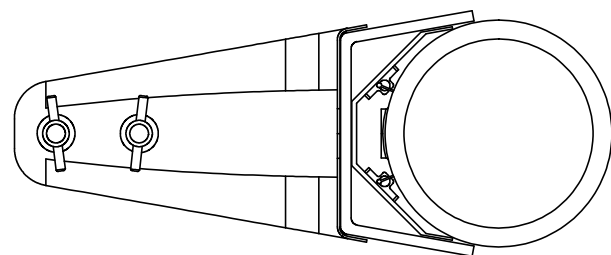

FINITURA: SHINY C-LOOK			INTERRUZIONE BORDI NETTI		NON SCALARE DISEGNO	REVISIONE 00	
CARBON EQUIPMENT						TITOLO: TENDER FENDER Model B	
DISEG. SD			FIRMA		N. DISEGNO		A3
VERIF. FM			DATA		MATERIALE: CARBONFIBRE EPOXY RESIN		
APPR.					PESO:		FOGLIO 1 DI 1
FABB.					SCALA: 1:20		
Qual.							

8 7 6 5 4 3 2 1